

SPECIFICATION		
1	Model No.	EST20N-A
2	Diaphragm	Mylar
3	Frame	Steel
4	Nominal Power:	0.25W
5	Maximum Power:	0.5W
6	Impedance:	4/8/16/32 ohm±15%Ω
7	Fo:	600 HZ
8	Response:	Fo-20kHz
9	S.P.L	87±3dB/0.1W/0.1
10	Magnet Size:	NdFeB
11	Rohs	Yes

THIS DOCUMENT CONTAINS DATE
 PROPRIETARY TO PROJECTS CHANGZHOU ESUNTECH
 CO LTD. ANY USE OR REPRODUCTION, IN ANY FORM,
 WITHOUT PRIOR WRITTEN PERMISSION OF
 PROJECTS CHANGZHOU ESUNTECH CO LTD
 IS PROHIBITED.
 ©2003, Project Changzhou Esuntech Co Ltd

REVISION HISTORY			
LTR	DESCRIPTION	DATE	APPROVED
-	RELEASED FROM ENGINEERING	9/23/2003	Y M
A			
B			
C			

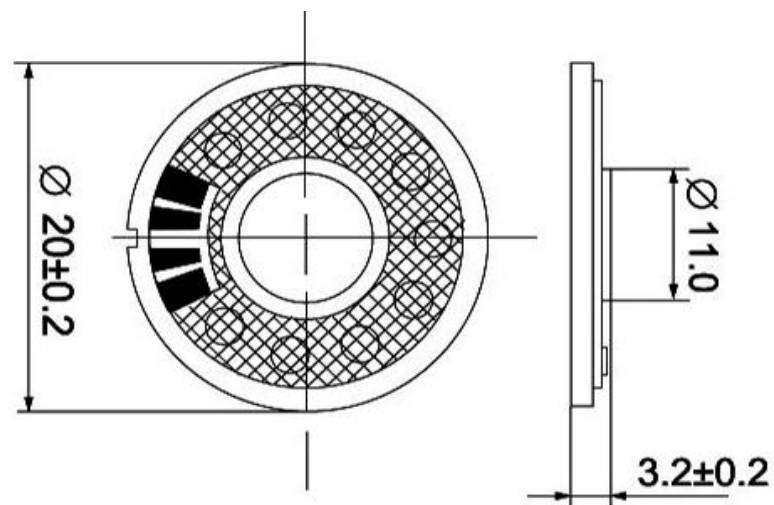
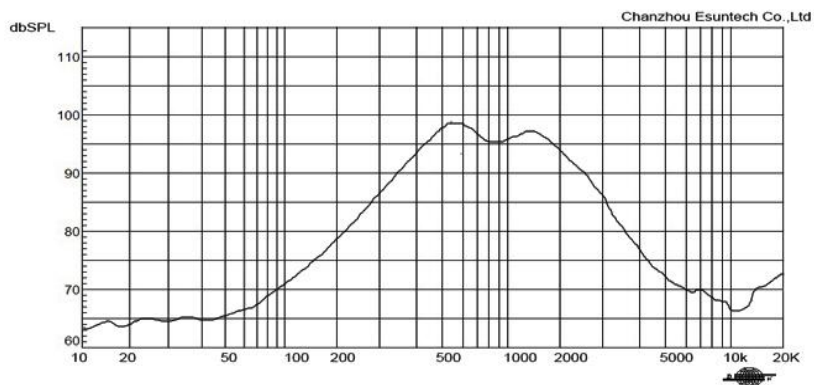

Package: 35x30x37cm/3kpcs/9kg/7.6kg/carton

NOTES:

- 1. ALL DIMENSIONS ARE IN MILLIMETERS
- 2. SPECIFICATIONS SUBJECT TO CHANGE WITHOUT NOTICE

SIZE	Designed by	Date	Checked by	Date	Approved by	Date	Drawed date
A4	 Changzhou Esuntech Co.,Ltd http://www.esuntech.com.cn			EST20N-A			
				SPEAKER	Edition	Sheet	

<http://www.esuntech.com.cn>

Email: esuntech@esuntech.com.cn

Tel: +86-519-8513 2681

Fax: +86-519-8513 2680